

**STORAGE CAPACITY**  
 91 - 20'x10' STORAGE UNITS  
 74 - 15'x10' STORAGE UNITS  
 8 - 35'x11' PARKING  
 4 - 27'x11'

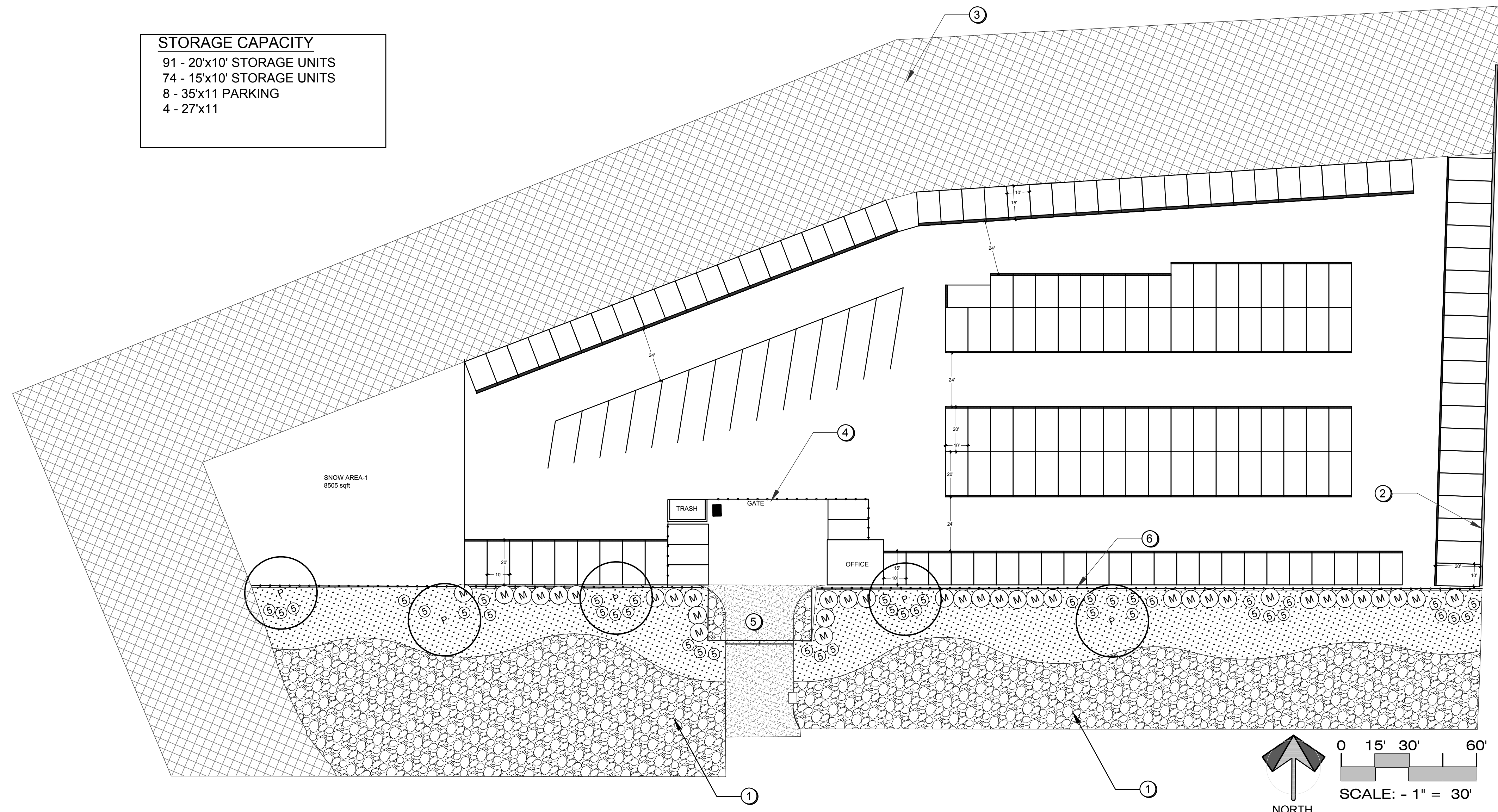

**PLANT LEGEND**

SYM	BOTANICAL NAME	COMMON NAME	SIZE	HTxSP	FORM	WATER USE
P	PINUS FLEXILIS	LIMBER PINE	24" BOX	25' x 20'	TREE	V.LOW
M	CERCOCARPUS LEDIFOLIUS	CARL LEAF MOUNTAIN MAHOGANY	15 GAL.	20' x 8'	COLUMNAR	V.LOW
B	BERBERIS THANGERGII 'ATROPURPUREA'	RED LEAF JAPANESE BARBERRY	5 GAL.	6' x 5'	SHRUB	V.LOW

**HYDROSEED FOR SNOW STORAGE AREA (IF DISTURBED)**

BOTANICAL NAME	COMMON NAME	LBS/ACRE	COVERAGE
PURSHIA TRIDENTADA	BITTERBRUSH	20 LBS	50%
ARTEMISIA TRIDENTADA	GREAT BASIN SAGE	10 LBS	25%
STIPA COMATA	NEEDLE AND THREAD	10 LBS	25%
TOTAL		40 LBS/ACRE	100%

- NOTES:**
- LANDSCAPE IS DESIGNED TO NATURALIZE OVER A PERIOD OF 3 YEARS. IRRIGATION SYSTEM SHALL BE TURNED OFF AFTER THAT ESTABLISHMENT PERIOD. THIS PLANT DESIGN SHALL MEET THE MAXIMUM POINTS ACHIEVED FOR LANDSCAPE REGARDING LEED (LEADERSHIP IN ENERGY EFFICIENT DESIGN) REQUIREMENTS VOLUNTARILY.
  - ANY DISTURBED SOIL DUE TO CONSTRUCTION SHALL BE RE-SEEDING WITH THE SPECIFIED HYDROSEED IN THE LEGEND.
  - NIGHTTIME LIGHTING IS NOT PERMITTED EXCEPT FOR ON MOTION SENSORS ONLY. ADHERE TO APPROVED LIGHTING CRITERIA.
  - MONUMENT SIGN TO ADHERE TO APPROVED SIGN CRITERIA.

- LEGEND**
- EXISTING 3/4" CRUSHED ROCK, SUPPLEMENT AS NEEDED FOR CONTINUOUS LOOK.
  - VERTICRETE WALL W/DARK BROWN SLATS PER REQUIEMENTS
  - EXISTING LANDSCAPE TO REMAIN PROTECT IN PLACE
  - ENTRY GATE W/ DARK BROWN SLATS
  - A/C PAVING
  - 6" BROWN VINYL COATED CHAIN LINK WITH BROWN SLATS

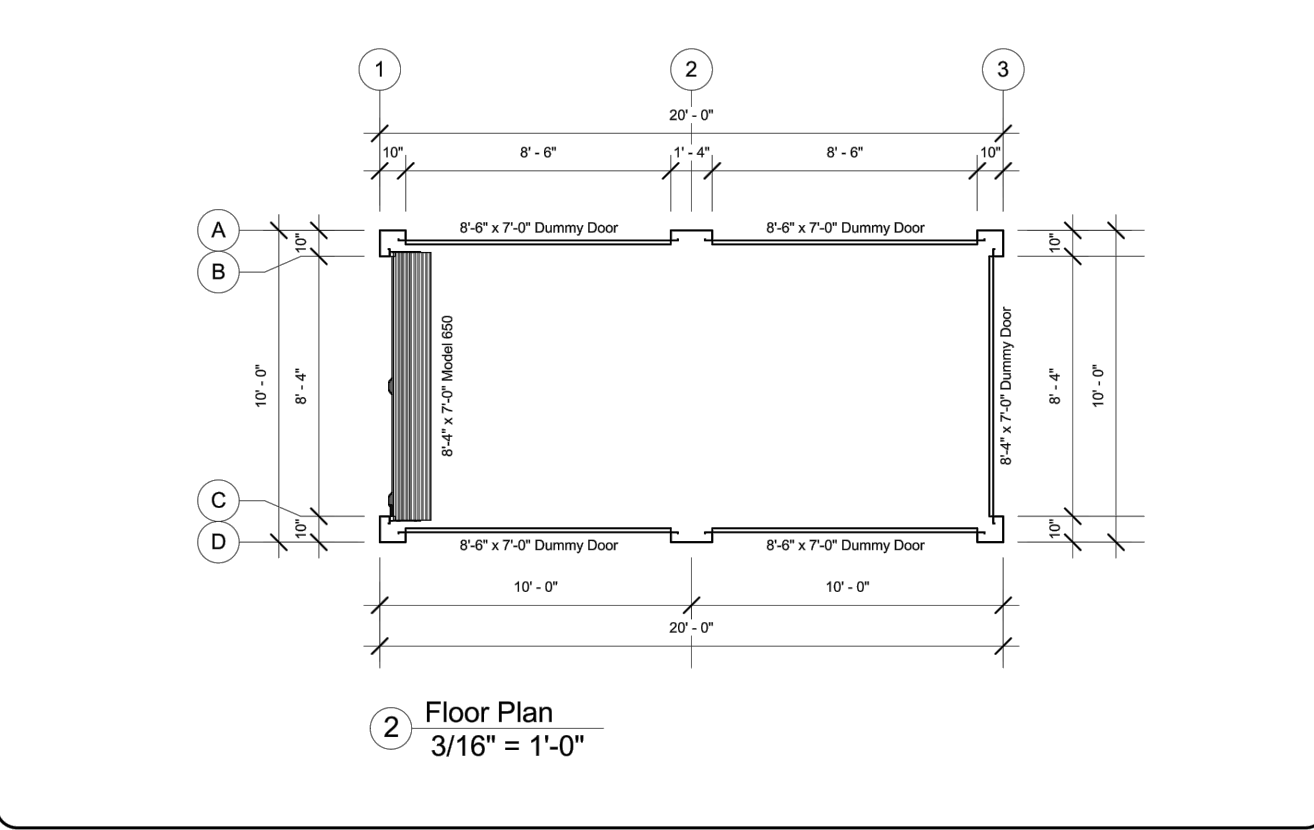
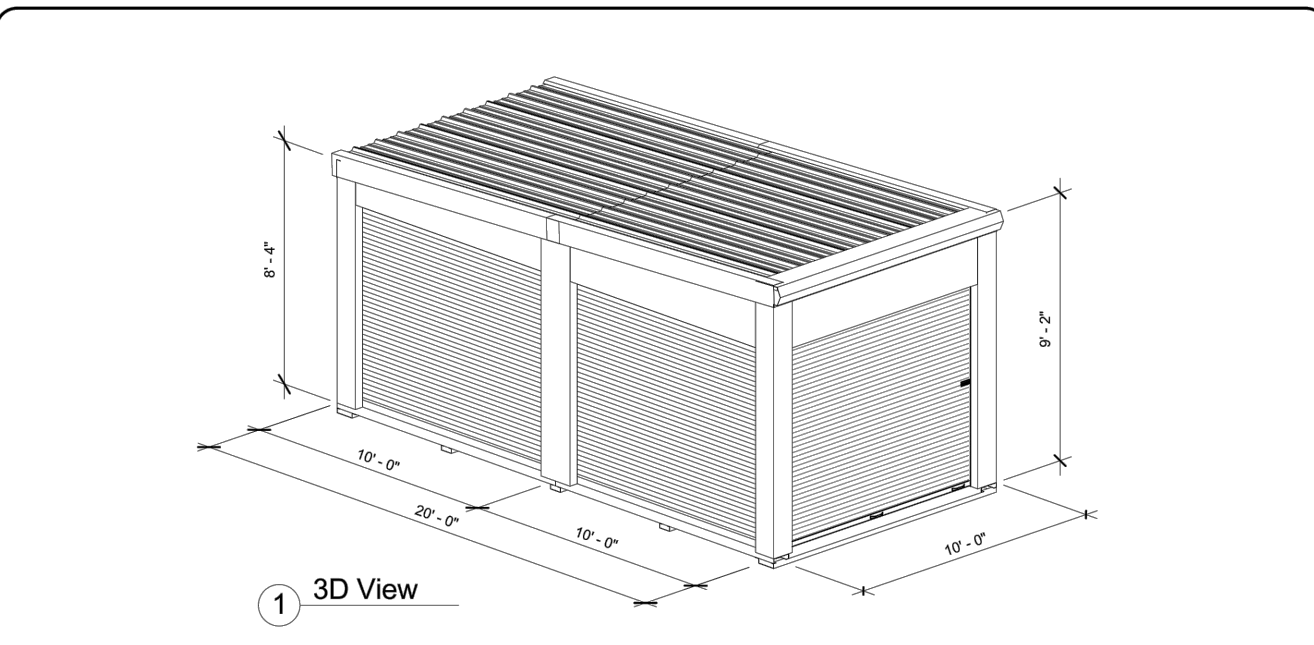

**10 x 20R-1F**  
 10 x 20 Single Unit Front Door

Drawn On: 4-22-2014  
 Project #: XXXX  
 Drawn By: B. Johnson  
 Checked By: D. Theut  
 Building Layout  
 BL - 1

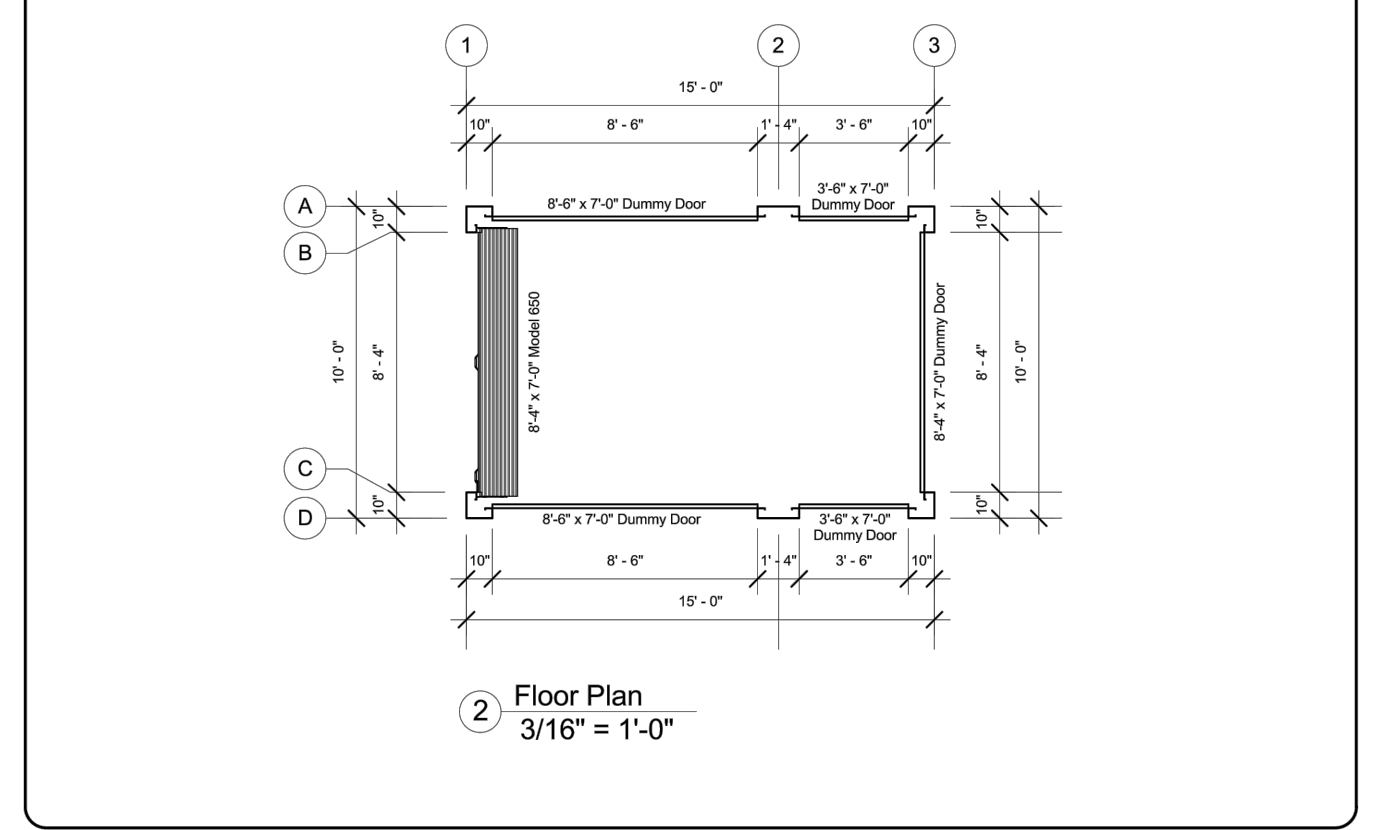
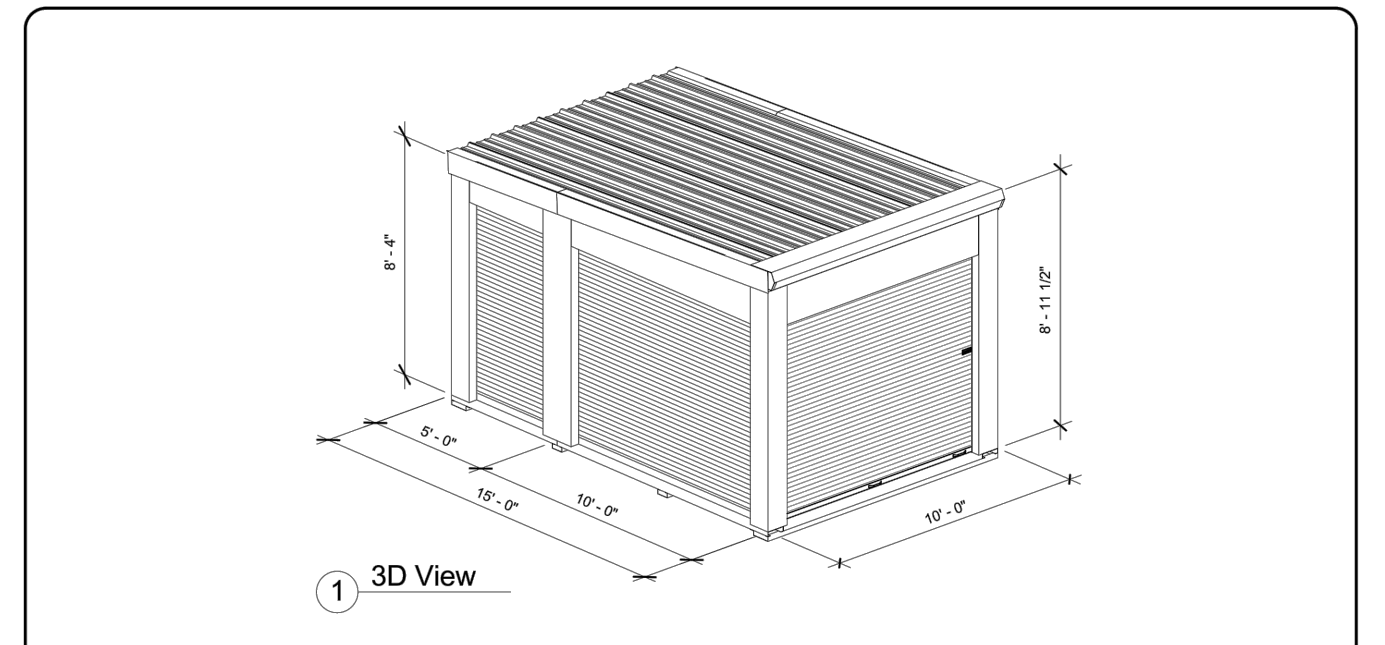

**10 x 15R-1F**  
 10 x 15 Single Unit Front Door

Drawn On: 4-22-2014  
 Project #: XXXX  
 Drawn By: B. Johnson  
 Checked By: D. Theut  
 Building Layout  
 BL - 1



CARL LEAF MOUNTAIN MAHOGANY



LIMBER PINE



3/4" CRUSHED ROCK



RED LEAF JAPANESE BARBERRY



**S.R. CLARKE**  
 LANDSCAPE ARCHITECTURE & DEVELOPMENT  
 P.O. BOX 100-PGM#407  
 MAMMOTH LAKES, CA 93546-0100  
 760-716-3100  
 CA. LLA#5299, C-27#944955

**DEVELOPER**  
 GREENS GLOBAL  
 CONTACT: NEIL KADAKIA  
 NEIL@GREENSGLOBAL.COM  
 PH (949) 546-0563  
 FAX (949) 546-0560

**APPLICANT**  
 S.R. CLARKE LANDSCAPE ARCHITECTURE & DEVELOPMENT  
 BOX 100-PGM #407  
 MAMMOTH LAKES, CA 93546-0100  
 CONTACT: SEAN CLARKE  
 EMAIL: SEAN@SRCLANDARC.COM  
 PH: (760) 716-3100

**PROJECT DATA**  
 ASSESSOR'S PARCEL NUMBER: 37-360-25.26.27.28  
 GROSS SITE AREA: 168,967 SF (3.67 AC)

SNOW STORAGE: AREA-1 8,505 SF



MAMMOTH LAKES  
 LANDSCAPE CONCEPT PLAN  
 FOR  
 SELF-STORAGE SITE

DATE: 06-15-17  
 SCALE: 1"=30"  
 SHEET \_\_\_\_  
 OF \_\_\_\_

NO.	DATE	REVISIONS